

# Features

## Unregulated Converters

- Power Sharing
- High Isolation 3kVDC & 4kVDC for 1 minute
- Efficiency up to 87%
- Wide Operating Temperature Range from -40°C to +85°C
- UL60950 Certified
- IEC/EN60950 Certified

### Description

The RKZ-xx2005D series features DC/DC converters which are especially designed for SiC mosfet drivers. The modules are available with input voltages of 5, 12, 15, or 24VDC with two asymmetric outputs of +20VDC and -5VDC. A special feature of this converter is output power sharing: the RKZ-xx2005D can be used with equal power (asymmetrical current) or equal current (asymmetrical power) loads. The modules offer 3kVDC or 4kVDC isolation. The operating temperature range of -40C to +100°C (with derating) meets harsh environmental requirements.

### Selection Guide

Part Number	Input Voltage [VDC]	Output Voltage [VDC]	Output Current [mA]	Efficiency typ. [%]	max. Capacitive Load <sup>(1)</sup> [µF]
RKZ-052005D	5	20/-5	50/-200 +/-80	86 85	100/1500
RKZ-122005D	12	20/-5	50/-200 +/-80	86	100/1500
RKZ-152005D	15	20/-5	50/-200 +/-80	86	100/1500
RKZ-242005D	24	20/-5	50/-200 +/-80	87	100/1500

#### Notes:

Note1: Max. capacitive load is tested at nominal input voltage and full load.

### Model Numbering

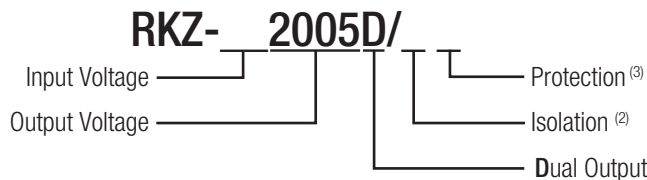

#### Notes:

- Note2: without suffix, standard 3kVDC isolation  
add suffix "/H" for higher 4kVDC isolation
- Note3: without suffix, without Short Circuit Protection  
add suffix "/P" for continuous short circuit protection

#### Examples:

- RKZ-052005D = 5Vin, 20/-5Vout, without SCP function + standard 3kVDC isolation
- RKZ-12005D/HP = 12Vin, 20/-5Vout, with continuous SCP function + high 4kVDC isolation

### Specifications (measured @ ta= 25°C, nominal Input and full load after warm-up time unless otherwise noted)

BASIC CHARACTERISTICS				
Parameter	Condition	Min.	Typ.	Max.
Input Voltage Range		-10%		+10%
Operating Frequency		20kHz		
Minimum Load			0%	
Output Ripple and Noise <sup>(4)</sup>			70mVp-p	150mVp-p

**Notes:**  
Note4: Ripple and Noise is measured with a 20MHz bandwidth and a 0.1µF ceramic capacitor.

continued on next page

## RKZ-xx2005D

### 2 Watt SIP7 for SiC Application

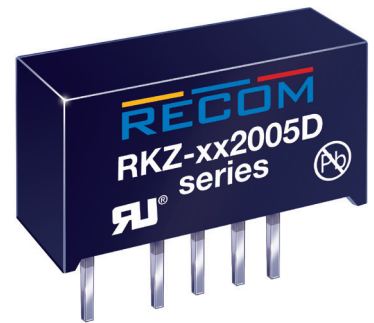

UL60950-1 Certified  
CSA C22.2 No. 60950-1-07  
IEC/EN60950-1 Certified  
EN55022

**Specifications** (measured @  $t_a = 25^\circ\text{C}$ , nominal Input and full load after warm-up time unless otherwise noted)

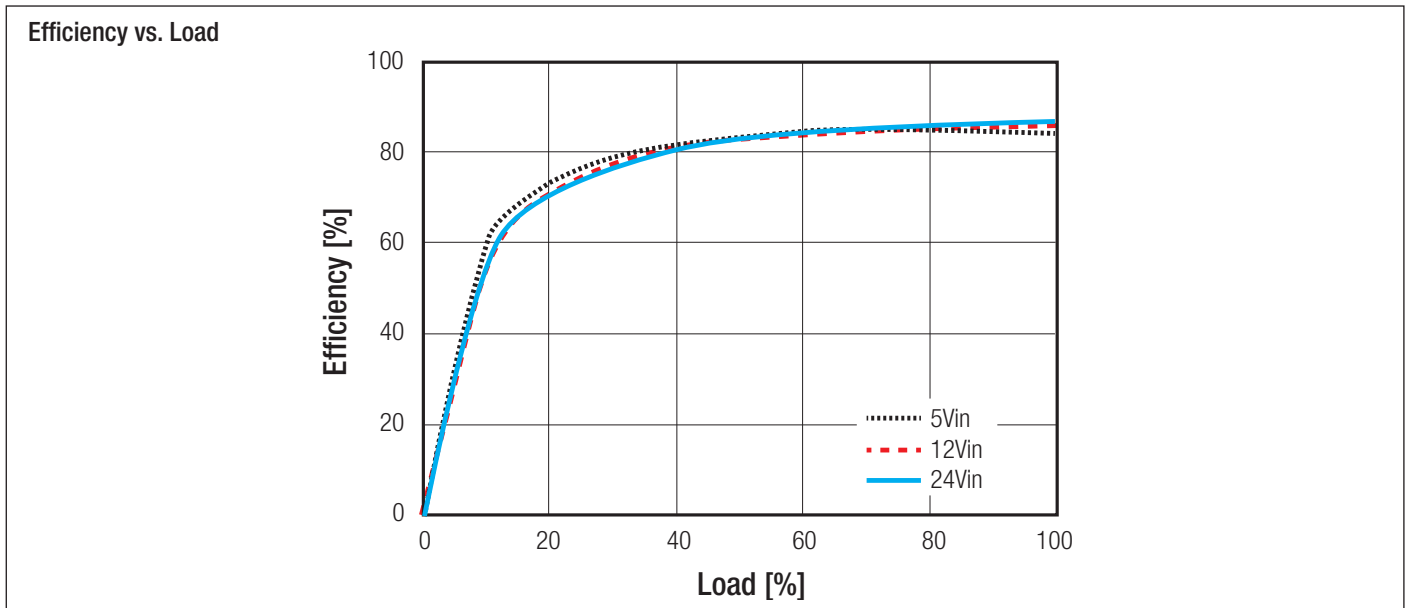

REGULATIONS		
Parameter	Condition	Values
Output Voltage Accuracy		±5% max.
Line Voltage Regulation	low line to high line, full load and 1%V <sub>in</sub>	±1.2% typ.
Load Voltage Regulation	10% to 100% load	±5% typ. / ±10% max.

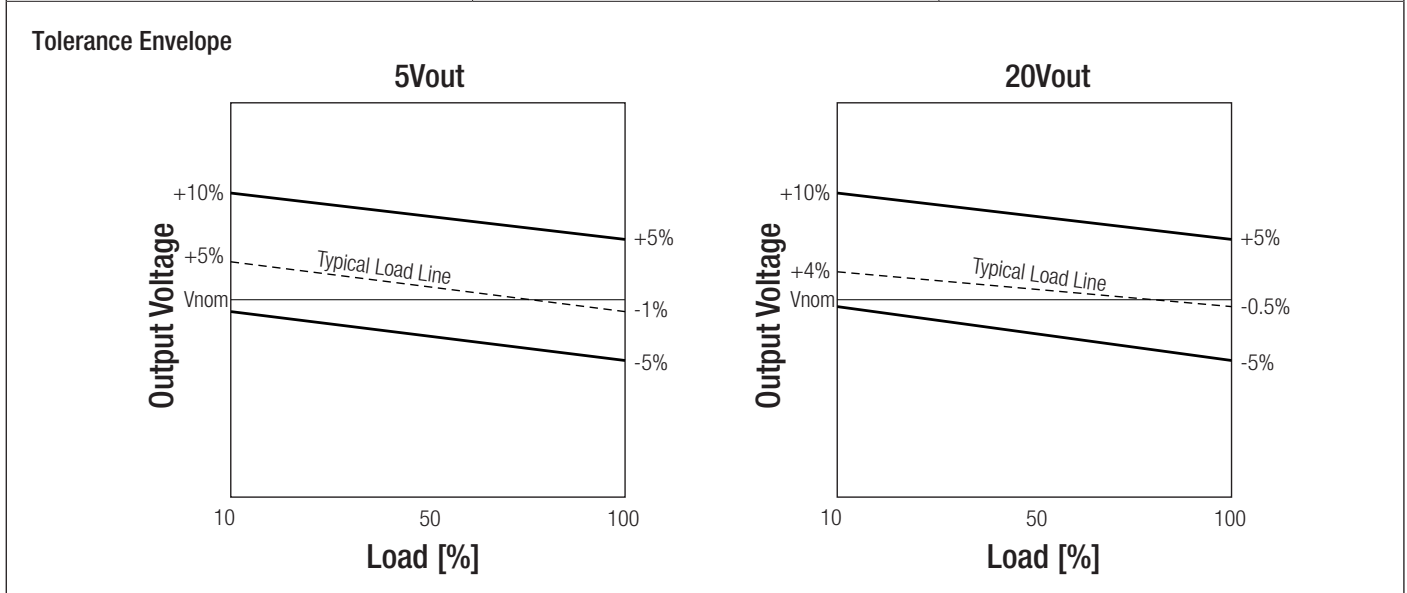

PROTECTIONS		
Parameter	Condition	Value
Short Circuit Protection (SCP)	only with "/P" suffix	continuous, automatic recovery
Isolation Voltage	I/P to O/P without suffix with suffix "/H"	3kVDC / 1 second 4kVDC / 1 second
Isolation Capacitance		135pF max.
Isolation Resistance		10GΩ min.

**Specifications** (measured @  $t_a = 25^\circ\text{C}$ , nominal Input and full load after warm-up time unless otherwise noted)

ENVIRONMENTAL		
Parameter	Condition	Value
Operating Temperature Range	free air convection, with derating	-40°C to +100°C
Operating Humidity	non-condensing	5% - 95% RH max.
Vibration		MIL-STD-202G
MTBF	according to MIL-HDBK-217F +25°C +85°C	1800 x 10 <sup>3</sup> hours 560 x 10 <sup>3</sup> hours

**Derating Graph**  
(@ nominal  $V_{in}$  at chamber and free air convection)

The graph plots Output Power [%] on the y-axis (0 to 100) against Ambient Temperature [°C] on the x-axis (-40 to 120). A horizontal line at 100% output power extends from -40°C to 85°C. From 85°C, the output power decreases linearly to 0% at 100°C. A vertical dashed line at 85°C and a horizontal dashed line at 100% define the 'Safe Operating Area'.

SAFETY AND CERTIFICATIONS		
Certificate Type	Report / File Number	Standard
UL General Safety	E358085-A4	UL60950-1, 2nd Edition, 2007
CAN/CSA General Safety		CSA C22.2 No. 60950-1-03, 2nd Edition, 2007
IEC/EN General Safety	LVD1602031	IEC/EN60950-1, 2nd Edition, 2013

EMI Compliance	Condition	Standard / Criterion
EMI	with external components (see filter suggestions)	EN55022, Class B

**EMC Filtering - Suggestions for Class B**

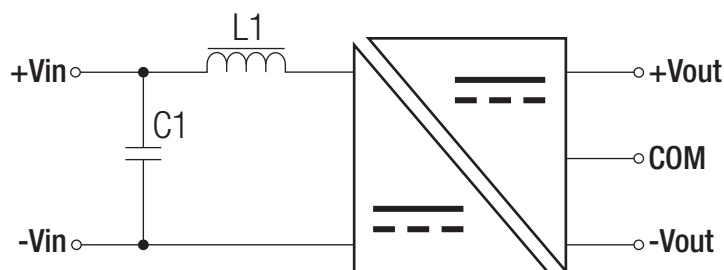

Input Voltage	C1	L1
5VDC	10 $\mu\text{F}$	4.7 $\mu\text{H}$
12VDC	4.7 $\mu\text{F}$	22 $\mu\text{H}$
15VDC	4.7 $\mu\text{F}$	22 $\mu\text{H}$
24VDC	2.2 $\mu\text{F}$	47 $\mu\text{H}$

**Specifications** (measured @  $t_a = 25^\circ\text{C}$ , nominal Input and full load after warm-up time unless otherwise noted)

### DIMENSION and PHYSICAL CHARACTERISTICS

Parameter	Type	Value
Material	Case Potting	Plastic, (UL94V-0) Epoxy, (UL94V-0)
Package Dimension (LxWxH)		19.65 x 7.05 x 10.2mm
Package Weight		2.8g

#### Dimension Drawing (mm)

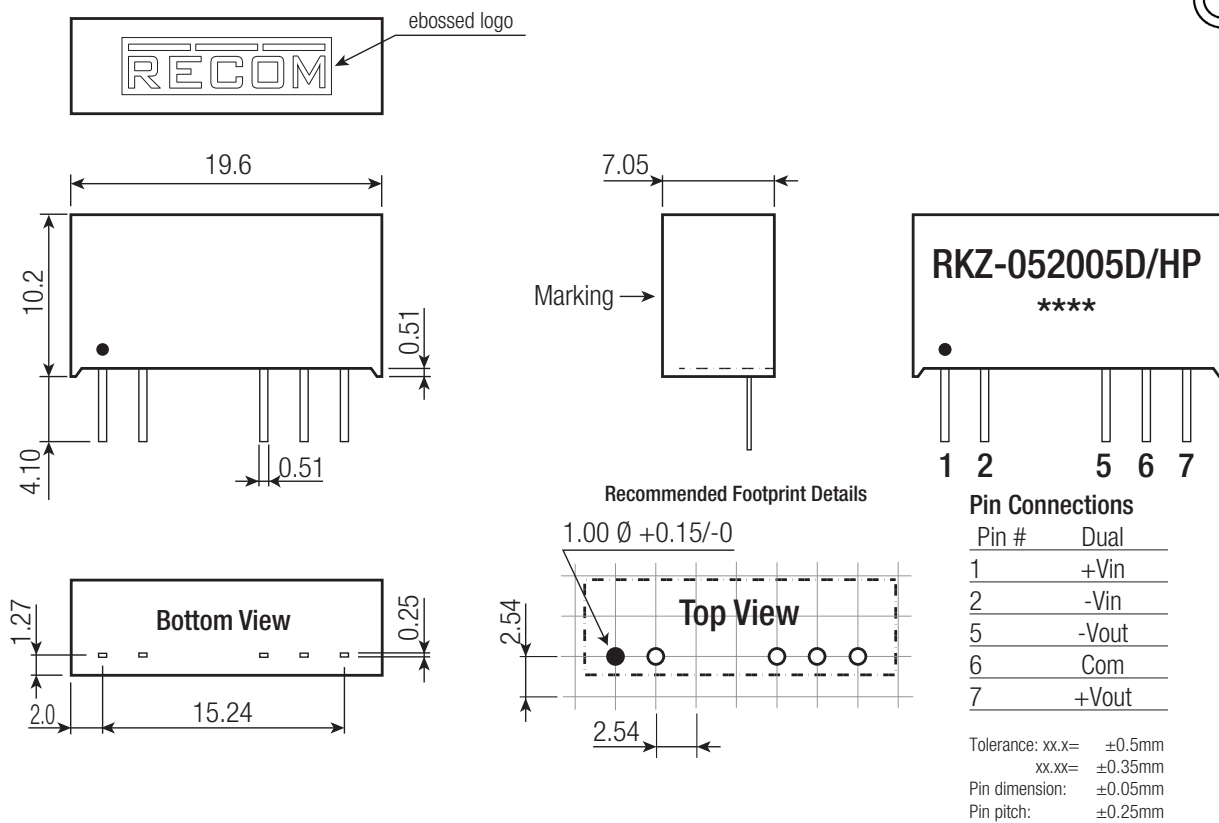

### INSTALLATION AND APPLICATION

#### Typical Application Circuit

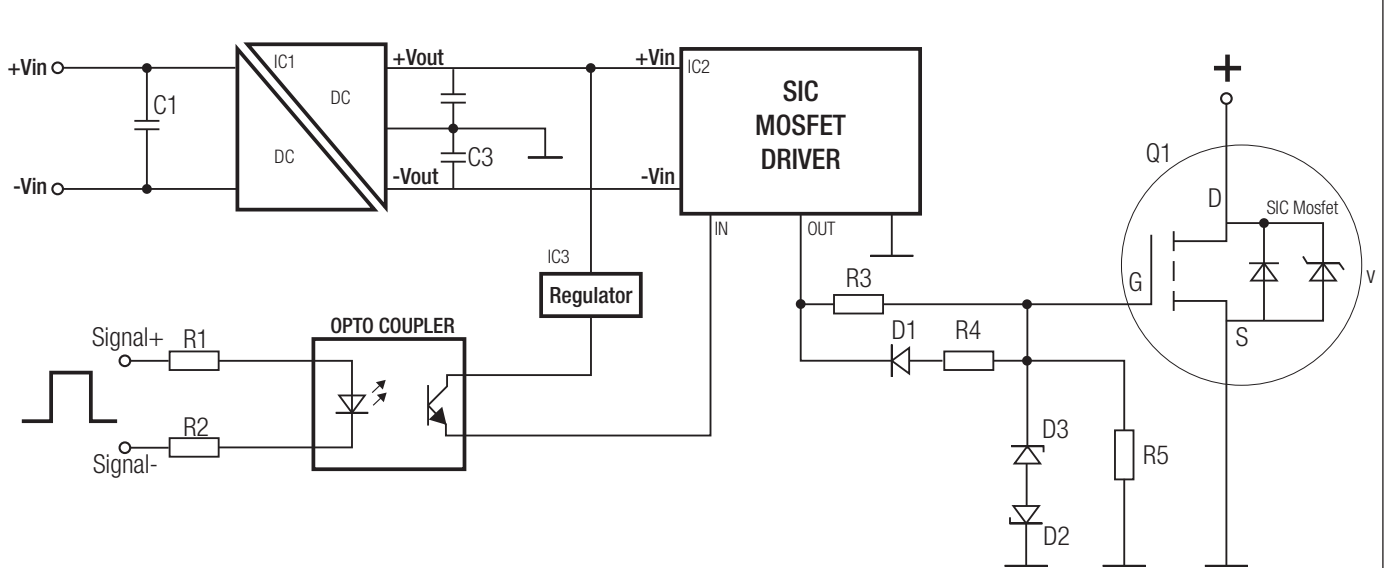

**Specifications** (measured @  $t_a = 25^\circ\text{C}$ , nominal input and full load after warm-up time unless otherwise noted)

PACKAGING INFORMATION		
Packaging Dimension (LxWxH)	Tube	520.0 x 16.5 x 9.3mm
Packaging Quantity		25pcs
Storage Temperature Range		-55°C to +125°C
Storage Humidity		5% to 95% RH